

TEKCELL

LITHIUM PRIMARY BATTERY



Tekcell, Always with you

VITZRO CELL
www.vitzrocell.com



C O N T E N T S

03	_ CEO Message
04	_ Company History
05	_ Certifications / Production Infrastructure
06	_ Our Solution
08	_ Feature
12	_ Products
27	_ EDLC Line Up
28	_ Military Pack
30	_ Battery Application Worksheet
31	_ Available Terminals
32	_ Technical List



Tekcell

L I T H I U M P R I M A R Y B A T T E R Y



Vitrocell (Tekcell Brand, a Korean Manufacturer) has been recognized as one of the best power solution providers of Lithium Primary Batteries in the world. We are proud of full-fledged range of products suitable for various applications such as Utility Meters (AMR), Asset Tracking, Security, Leak Detector, and Military Devices & Equipment. Based on more than 20 years of accumulated expertise equipped with ISO9001, ISO14001, UL and others, we have achieved a leading position in the global markets through creative R&D resources, vertically integrated production facilities, reliable products, on-time delivery, and superb technical service. In this context, we do have very close relationship with lots of valuable partners and customers in more than 50 countries.

“Vitzrocell, a leader of portable power solutions!”

Vitzrocell has been recognized as one of the best power solution providers and the most reliable manufacturers of Lithium Primary Batteries in the world. We're proud of the full-fledged range of products suitable for various application. And our teammates of R&D, Marketing & Sales, Factory, and so on is duly ready and resourceful enough to offer the added value which you have not had taste before. Based on more than 21 years of accumulated know-how, we are glad to have achieved a leading position in the world wide markets.

Considering the remarkable growing demand for portable power solutions and our continuous innovation activities, we're convinced that Vitzrocell will be able to make our valuable customers, partners, and the stakeholders happy with the enduring profitable growth with Vitzrocell. We humbly would like to invite you to enjoy and share the promising business opportunity with us as a strategic Partner.

VITZROCELL President Paul Jang



Vision

Longing for Happy Life of Vitzrocell Family and all the other stakeholders.(3S)

Mission

To Enhance Smart, Safe, and Green World as a dedicated power solution provider.

COMPANY HISTORY



We are Moving forward from GOOD to GREAT

1987~1993_ Build the basis for a specialized company in the lithium battery field

- Oct. 1987 Founded the Company
- May. 1988 Technical Alliance with Wilson Great batch for Lithium Battery
- Oct. 1993 Won the contract as a Sole Manufacturer for the Korean Military

1994~ 2004_ Build the solid basis for a leading technology company

- Jul. 2000 Enlisted Venture Company with new Technology
- Jun. 2002 Launched New Company name as "VITZROCELL"
- Jun. 2004 Awarded USD 10M on the export/Ministry of commerce, industry and resources

2005~_ Powerful leap towards the global TOP

- Apr. 2005 Awarded "Advanced Technology and R&D center" by Ministry of Commerce in Korea.
- Mar. 2006 ISO-1400 Approval
- Nov. 2007 Certificate of Defense Quality Management System by Defense Agency for Technology and Quality (DTaQ)
- Nov. 2009 Awarded "the Technology Fast 500 "by Deloitte Touche Tohmatsu
- Sep. 2010 Awarded "Enterprise with Best Labor Management Culture 2010 " from Ministry of Labor.
- Sep. 2010 Awarded USD 20M export/Ministry of commerce, industry and resources

TS_16949, TS_ISO 9001, ISO 14001, IS 9001, Certificate of Advanced Technology Center Defense Agency for Technology & Quality



PRODUCTION INFRASTRUCTURE

100% self-developed facilities & large-scale production infra.

Vertical Systematization (Full Automation)

Vertical production for core parts like Lithium, Electrolyte etc

Factory in Ye-san

- Land Area : 11,330 m²
- Building Area : 4,349 m²
- Yearly Production Capa : 40M (CELL)

100% self-developed automatic facilities

OUR SOLUTION

Power Solution for Next Generation

VITZROCELL has products suitable for various applications including Utility Meter (AMR), Asset Tracking, Security, Leak Detector and Military Devices & Equipments. In addition, we are currently expanding our business in the military market and increasing the sales in AMR market. VITZROCELL is constantly planning new businesses including RFID Tag of heavy equipments and containers, Toll Pass equipments, wireless terminals, ocean equipments, new electronic appliances and medical devices.



ASSET TRACKING

Animal tracking

MILITARY SYSTEM

Night Goggles

Radio System

RFID Tag

UBIQUITOUS

Toll pass

TPMS

PIG (Pipeline inspection gauge)

Location Tracking System

OCEAN EQUIPMENT



Buoy



Life Jacket



Tsunami Detector

OIL & GAS EXPLORATION



MWD(Measurement While Drilling)

ASSET TRACKING



Container Tracking

SMART GRID



Medical Equipments

Home Security system

- AMR (Automatic meter reading)
- Gas Meter
- Water Meter
- Electricity Meter

FEATURE

Optimum Solution Provider adopting the best solution!
Becoming a leading firm in the global market!



Creating Better Life



⦿ The lithium thionyl chloride battery

- High and stable operating voltage** The TEKCELL lithium batteries have a nominal voltage of 3.6 Volts, which is considerably higher than any other commercially available battery.
- Wide temperature range** The batteries are capable of operating in a wide temperature range normally from -55° C ~ +85° C.
- Low self-discharge rate** Less than 1% self-discharge after 1 year storage at + 20° C
- High energy density** The electrochemical system offers the highest energy density of any available primary battery: up to 650Wh/kg and 1,280Wh/dm³
- Ultimate safety** All of the TEKCELL primary lithium batteries are UL recognized, and meet UN transportation test requirements.
- Extensive Shelf Life** TEKCELL lithium batteries offer prolonged storage with a proven shelf life of 10 years when stored at normal room temperature.

⦿ Comparison with other battery types

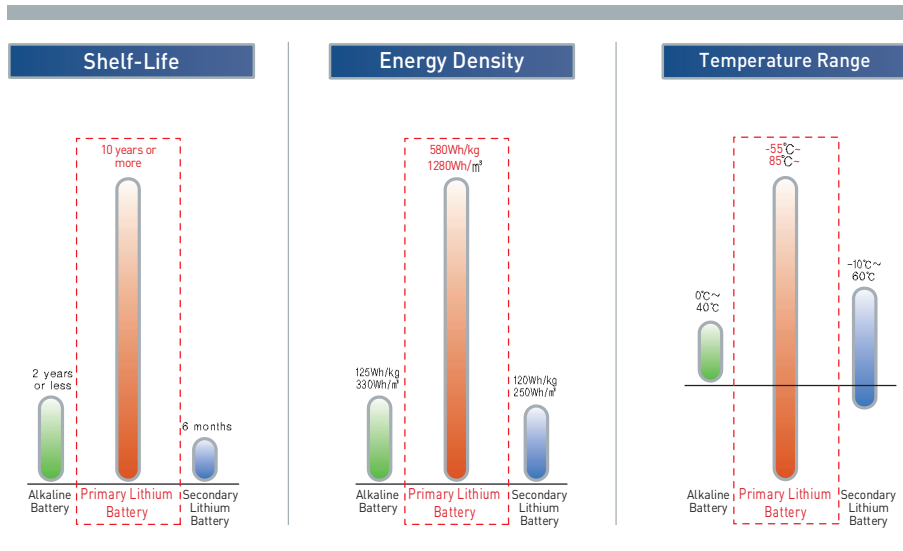

⦿ Mechanism for reaction of Li/SOCl₂ Battery

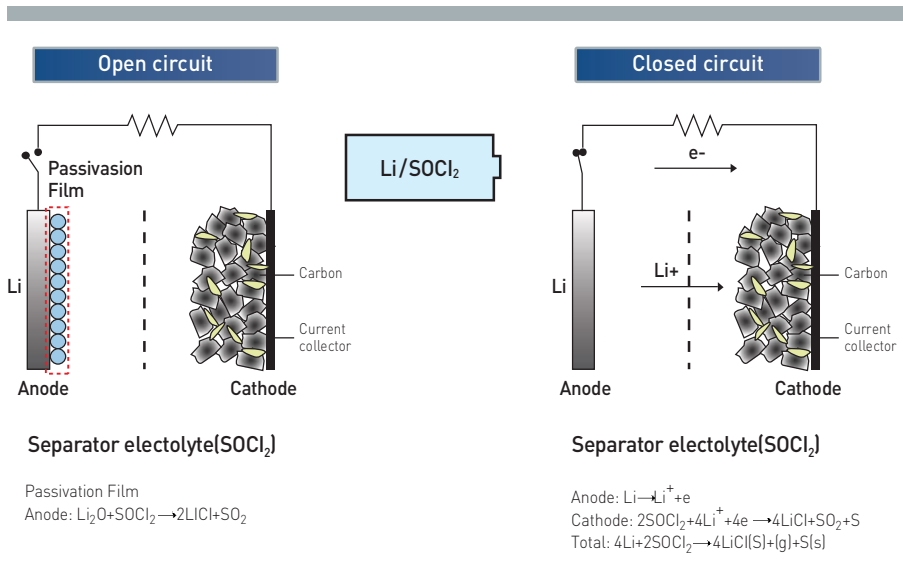

FEATURE

Transient Minimum Voltage (TMV)

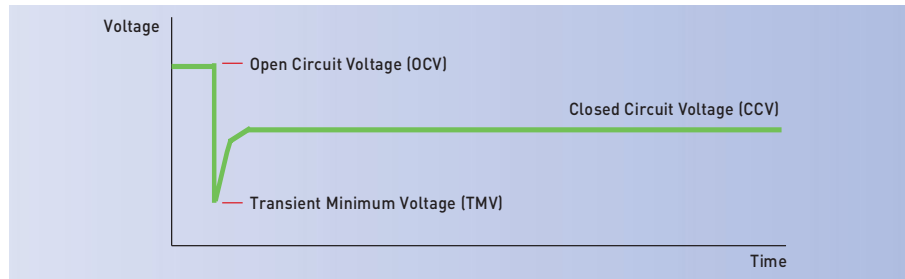

Lithium thionyl chloride battery has very low self discharge rate than other conventional batteries. That is due to the passivation layer (LiCl film) formed on the lithium surface. This layer effectively prevents the self-discharge of the lithium as it is nonconductive. Therefore, this layer should be broken at the initial stage of discharge to allow lithium ion to flow to lithiumion. In the process, the layer adds to internal resistance, causing a momentary voltage drop, which is called TMV (Transient Minimum Voltage). The voltage of cells kept under proper conditions immediately recovers to normal operational voltage after TMV. TMV varies depending on the thickness and density of the passivation layer. The higher the discharge current gets, the lower TMV becomes. The passivation layer extends the shelf life by effectively preventing self-discharge but it brings about TMV. Thus, TMV must be fully considered, when a device is being designed.

Construction

Li/SOC12 Bobbin type

Application of Low Current drain

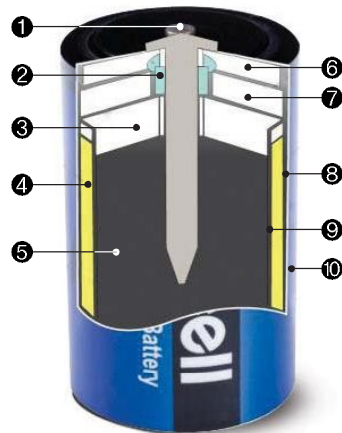

- ① Positive Pin&Current Collector
- ② Glass-to-Metal Seal ③ Insulator ④ Anode
- ⑤ Cathode ⑥ Spacer ⑦ Header Base
- ⑧ Case ⑨ Separator ⑩ Shrinkable Tube

Strength

- High Safety Level
- Very Low Self Discharge Rate
- High Energy Density
- Excellent Operating Life

Weakness

- Low Power
- High Passivation (Voltage Delay)

Li/SOC12 Spiral type

Application of High Current drain

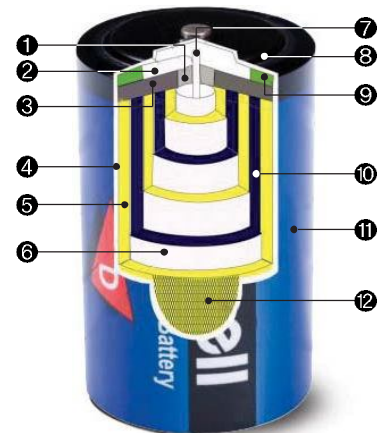

- ① Glass-to-Metal Seal ② Cell Tuse
- ③ Header Base ④ Case ⑤ Anode
- ⑥ Separator ⑦ Positive pin ⑧ Terminal Cap
- ⑨ Spacer ⑩ Cathode ⑪ Shrinkable Tube
- ⑫ Current Collector

Strength

- High Power
- Low Passivation (Voltage Delay)

Weakness

- Low Safety Level
- Low Self Discharge Rate
- Low Operating Life
- Low Energy Density

Hybrid Battery Technology as Pulse Assist



Vitzro Hybrid Battery

Hybrid Battery Type		Characteristic of Pulse Assist	Performance		
Main Power	Pulse Assist		Load of Battery	Working Voltage	Life of Battery
Primary Battery	Electrolytic Capacitor	Small capacitance	High	Low	Short
	Li 2nd Battery	Bad charge efficiency Limitation of Power	Middle	Middle	Middle
	Vitzrocap.	Ultra low resistance Excellent charge efficiency	Low	High	Long

※ High Power Vitzrocap.
 High Efficiency: EDLC (Electric Double Layer Capacitor) of physical reaction
 High Power Design: Carbon electrode as thin film and high power combination

Comparison between Vitzrocap. and Li 2nd Battery

The Comparison of General Characteristics

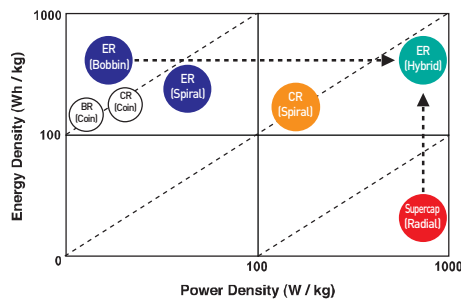

Pulse Test Power Profile

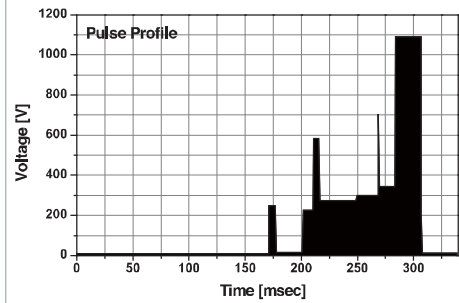

Comparison of Pulse Performance as Temperature

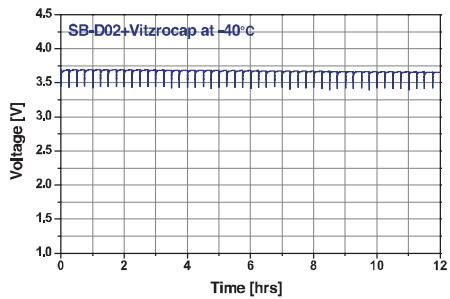
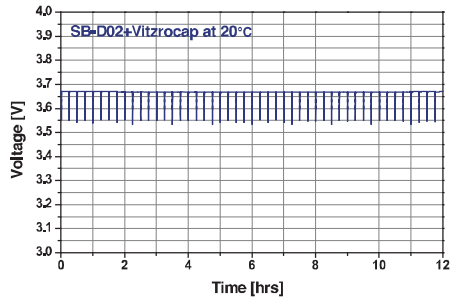

Hybrid battery discharge

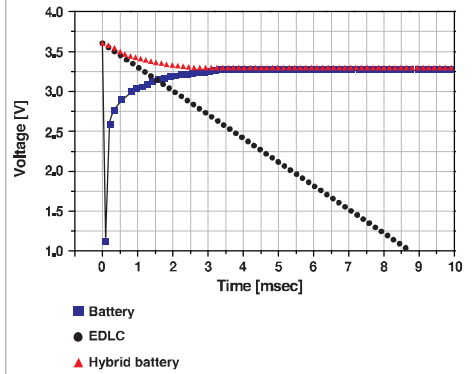

LITHIUM PRIMARY BATTERY

SB-AA02



Key Characteristics

- High and stable operating voltage
- Low self-discharge rate (less than 1% after 1 year of storage at +20°C)
- Bobbin type
- Non-flammable inorganic electrolyte
- Hermetic glass-to-metal sealing
- UL recognized (file number MH18384)
- RoHS Compliance
- Non-restricted for transport



External Dimensions

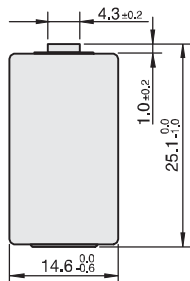

※ Available Terminals :
TC ST 2P 3P 3PW AX Other
type available by request

Specifications

Model	SB-AA02
Nominal voltage	3.6V
Nominal capacity (at 1mA, 20°C, 2.0V cut off)	1.2Ah
Maximum recommended continuous current (Higher currents are possible, consult Vitzrocell)	20mA
Max. pulse discharge current	50mA
Weight	9.0g
Operating temperature range	-55 ~ 85°C

※ Max. pulse current/0.1 second pulses, drained every 2 min at +20°C from undischarged cells with 10 μA base current, yield voltage readings above 3.0V. The readings may vary according to the pulse characteristics, the temperature, and the cell's previous history.
Fitting the cell with a capacitor may be recommended in severe conditions. Consult Vitzrocell.

Characteristic Curve

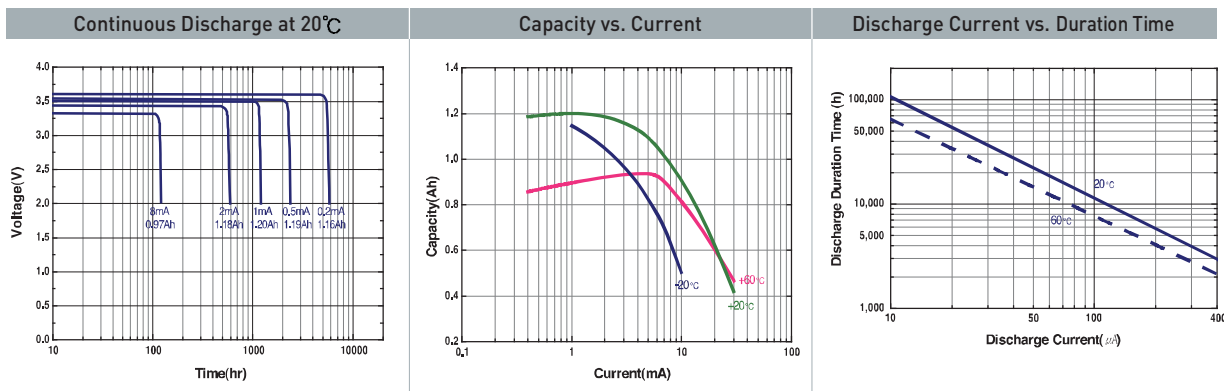

※ This data was made on basis of nominal capacity for the purpose of enabling users to forecast approximate life time. In order to calculate precise life time under various environment, we recommend you to consult Vitzrocell.

Warning

Fire, explosion and severe burn hazard. Do not recharge, crush, disassemble, heat above 212°F (100°C), incinerate, short circuit or expose contents to water. Keep battery out of reach of children and in original package until ready to use. Dispose of used batteries promptly.

※ Any information given here is for reference only. Information is also dependent on actual conditions of use and does not guarantee future performance, and subject to change.

LITHIUM PRIMARY BATTERY

SB-AA02(P)



Key Characteristics

- High and stable operating voltage
- Superior voltage response during pulsing
- Low self-discharge rate (less than 1% after 1 year of storage at +20°C)
- Bobbin type
- Non-flammable inorganic electrolyte
- Hermetic glass-to-metal sealing
- UL recognized (file number MH18384)
- RoHS Compliance
- Non-restricted for transport



External Dimensions

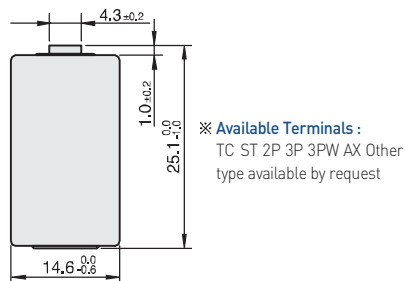

Specifications

Model	SB-AA02(P)
Nominal voltage	3.6V
Nominal capacity (at 1mA, 20°C, 2.0V cut off)	1.2Ah
Maximum recommended continuous current (Higher currents are possible, consult Vitzrocell)	20mA
Max. pulse discharge current	80mA
Weight	9.0g
Operating temperature range	-55 ~ 85°C

※ Max. pulse current/0.1 second pulses, drained every 2 min at +20°C from undischarged cells with 10 μ A base current, yield voltage readings above 3.0V. The readings may vary according to the pulse characteristics, the temperature, and the cell's previous history.
Fitting the cell with a capacitor may be recommended in severe conditions. Consult Vitzrocell.

Characteristic Curve

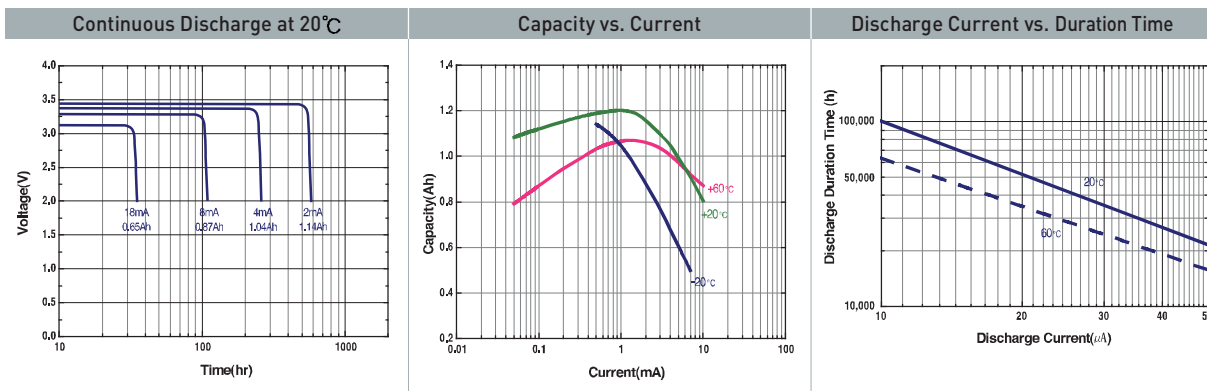

※ This data was made on basis of nominal capacity for the purpose of enabling users to forecast approximate life time.
In order to calculate precise life time under various environment, we recommend you to consult Vitzrocell.

Warning

Fire, explosion and severe burn hazard. Do not recharge, crush, disassemble, heat above 212°F(100°C), incinerate, short circuit or expose contents to water. Keep battery out of reach of children and in original package until ready to use. Dispose of used batteries promptly.

※ Any information given here is for reference only. Information is also dependent on actual conditions of use and does not guarantee future performance, and subject to change.

LITHIUM PRIMARY BATTERY

SB-AA11



Key Characteristics

- High and stable operating voltage
- Low self-discharge rate (less than 1% after 1 year of storage at +20°C)
- Bobbin type
- Non-flammable inorganic electrolyte
- Hermetic glass-to-metal sealing
- UL recognized (file number MH18384)
- RoHS Compliance
- Non-restricted for transport



External Dimensions

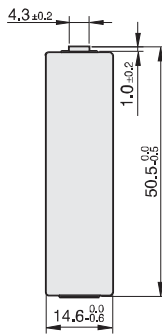

※ Available Terminals :
TC ST 2P 3P 3PW AX Other
type available by request

Specifications

Model	SB-AA11
Nominal voltage	3.6V
Nominal capacity (at 2mA, 20°C, 2.0V cut off)	2.5Ah
Maximum recommended continuous current (Higher currents are possible, consult Vitzrocell)	60mA
Max. pulse discharge current	100mA
Weight	16.0g
Operating temperature range	-55 ~ 85°C

※ Max. pulse current/0.1 second pulses, drained every 2 min at +20°C from undischarged cells with 10 μA base current, yield voltage readings above 3.0V. The readings may vary according to the pulse characteristics, the temperature, and the cell's previous history.
Fitting the cell with a capacitor may be recommended in severe conditions. Consult Vitzrocell.

Characteristic Curve

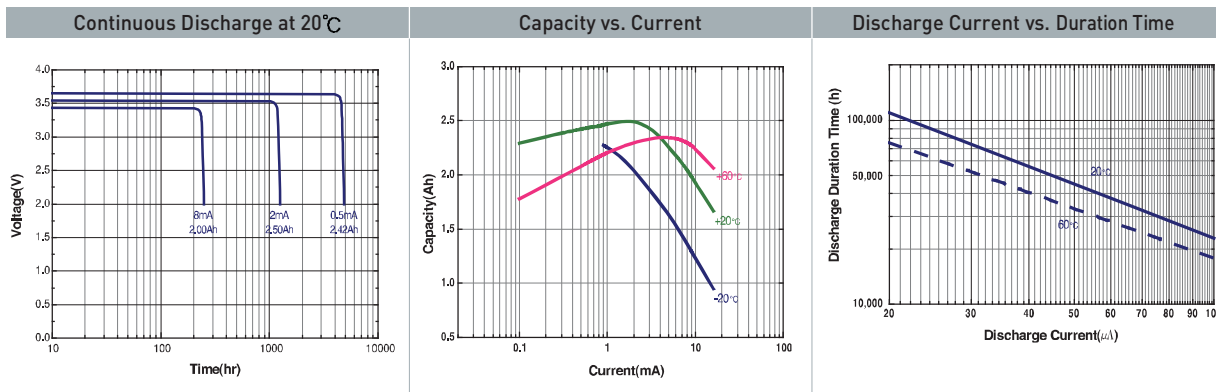

※ This data was made on basis of nominal capacity for the purpose of enabling users to forecast approximate life time.
In order to calculate precise life time under various environment, we recommend you to consult Vitzrocell.

Warning

Fire, explosion and severe burn hazard. Do not recharge, crush, disassemble, heat above 212°F (100°C), incinerate, short circuit or expose contents to water. Keep battery out of reach of children and in original package until ready to use. Dispose of used batteries promptly.

※ Any information given here is for reference only. Information is also dependent on actual conditions of use and does not guarantee future performance, and subject to change.

LITHIUM PRIMARY BATTERY

SB-AA11(P)



Key Characteristics

- High and stable operating voltage
- Superior voltage response during pulsing
- Low self-discharge rate (less than 1% after 1 year of storage at +20°C)
- Bobbin type
- Non-flammable inorganic electrolyte
- Hermetic glass-to-metal sealing
- UL recognized (file number MH18384)
- RoHS Compliance
- Non-restricted for transport



External Dimensions

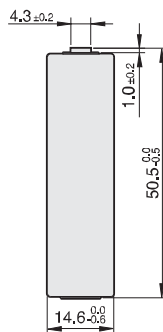

※ Available Terminals :
TC ST 2P 3P 3PW AX Other
type available by request

Specifications

Model	SB-AA11(P)
Nominal voltage	3.6V
Nominal capacity (at 2mA, 20°C, 2.0V cut off)	2.5Ah
Maximum recommended continuous current (Higher currents are possible, consult Vitzrocell)	60mA
Max. pulse discharge current	150mA
Weight	16.0g
Operating temperature range	-55 ~ 85°C

※ Max. pulse current/0.1 second pulses, drained every 2 min at +20°C from undischarged cells with 10 μA base current, yield voltage readings above 3.0V. The readings may vary according to the pulse characteristics, the temperature, and the cell's previous history.
Fitting the cell with a capacitor may be recommended in severe conditions. Consult Vitzrocell.

Characteristic Curve

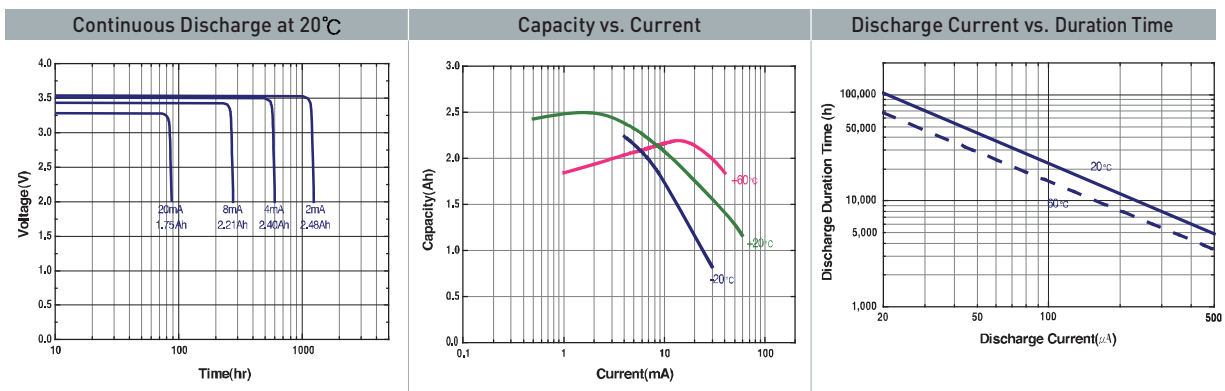

※ This data was made on basis of nominal capacity for the purpose of enabling users to forecast approximate life time.
In order to calculate precise life time under various environment, we recommend you to consult Vitzrocell.

Warning

Fire, explosion and severe burn hazard. Do not recharge, crush, disassemble, heat above 212°F(100°C), incinerate, short circuit or expose contents to water. Keep battery out of reach of children and in original package until ready to use. Dispose of used batteries promptly.

※ Any information given here is for reference only. Information is also dependent on actual conditions of use and does not guarantee future performance, and subject to change.

LITHIUM PRIMARY BATTERY

SB-A01



Key Characteristics

- High and stable operating voltage
- Low self-discharge rate (less than 1% after 1 year of storage at +20°C)
- Bobbin type
- Non-flammable inorganic electrolyte
- Hermetic glass-to-metal sealing
- UL recognized (file number MH18384)
- RoHS Compliance
- Non-restricted for transport



External Dimensions

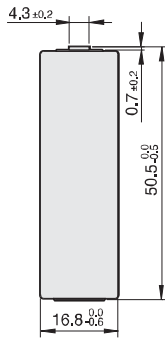

※ Available Terminals :
TC ST AX Other type
available by request

Specifications

Model	SB-A01
Nominal voltage	3.6V
Nominal capacity (at 3mA, 20°C, 2.0V cut off)	3.65Ah
Maximum recommended continuous current (Higher currents are possible, consult Vitzrocell)	70mA
Max. pulse discharge current	160mA
Weight	24.0g
Operating temperature range	-55 ~ 85°C

※ Max. pulse current/0.1 second pulses, drained every 2 min at +20°C from undischarged cells with 10 μA base current, yield voltage readings above 3.0V. The readings may vary according to the pulse characteristics, the temperature, and the cell's previous history.
Fitting the cell with a capacitor may be recommended in severe conditions. Consult Vitzrocell.

Characteristic Curve

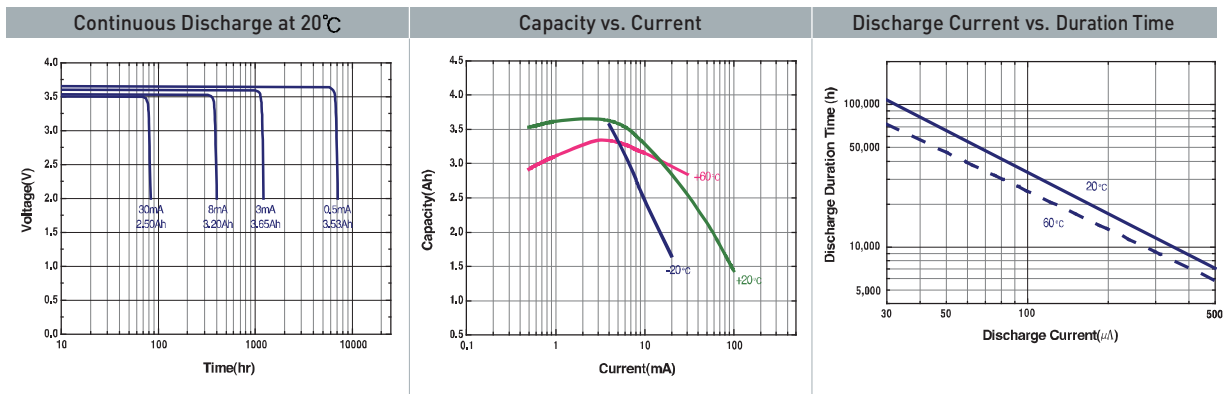

※ This data was made on basis of nominal capacity for the purpose of enabling users to forecast approximate life time.
In order to calculate precise life time under various environment, we recommend you to consult Vitzrocell.

Warning

Fire, explosion and severe burn hazard. Do not recharge, crush, disassemble, heat above 212°F(100°C), incinerate, short circuit or expose contents to water. Keep battery out of reach of children and in original package until ready to use. Dispose of used batteries promptly.

※ Any information given here is for reference only. Information is also dependent on actual conditions of use and does not guarantee future performance, and subject to change.

LITHIUM PRIMARY BATTERY

SB-C02



Key Characteristics

- High and stable operating voltage
- Low self-discharge rate (less than 1% after 1 year of storage at +20°C)
- Bobbin type
- Non-flammable inorganic electrolyte
- Hermetic glass-to-metal sealing
- UL recognized (file number MH18384)
- RoHS Compliance



External Dimensions

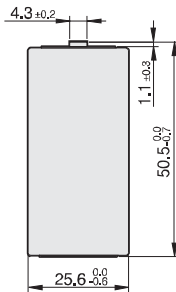

※ Available Terminals :
TC ST AX Other type
available by request

Specifications

Model	SB-C02
Nominal voltage	3.6V
Nominal capacity (at 4mA, 20°C, 2.0V cut off)	8.5Ah
Maximum recommended continuous current (Higher currents are possible, consult Vitzrocell)	80mA
Max. pulse discharge current	180mA
Weight	51.0g
Operating temperature range	-55 ~ 85°C

※ Max. pulse current/0.1 second pulses, drained every 2 min at +20°C from undischarged cells with 10 μ A base current, yield voltage readings above 3.0V. The readings may vary according to the pulse characteristics, the temperature, and the cell's previous history.
Fitting the cell with a capacitor may be recommended in severe conditions. Consult Vitzrocell.

Characteristic Curve

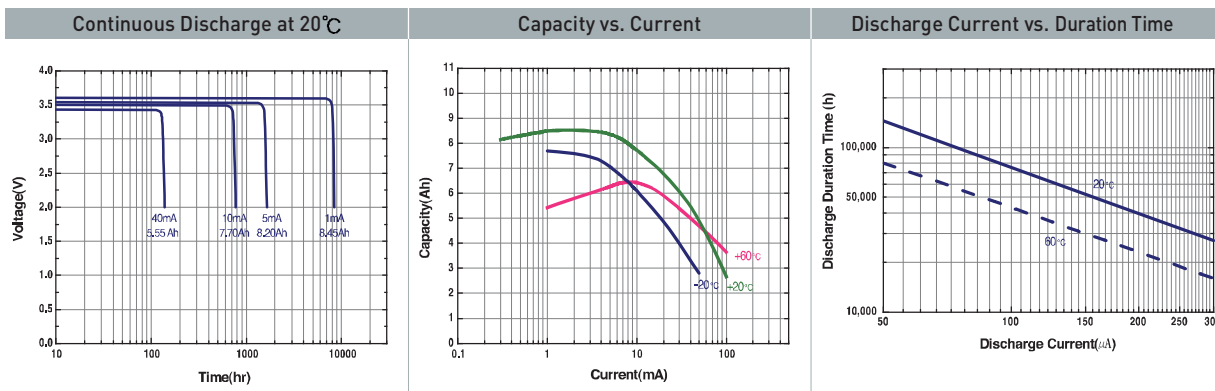

※ This data was made on basis of nominal capacity for the purpose of enabling users to forecast approximate life time.
In order to calculate precise life time under various environment, we recommend you to consult Vitzrocell.

Warning

Fire, explosion and severe burn hazard. Do not recharge, crush, disassemble, heat above 212°F(100°C), incinerate, short circuit or expose contents to water. Keep battery out of reach of children and in original package until ready to use. Dispose of used batteries promptly.

※ Any information given here is for reference only. Information is also dependent on actual conditions of use and does not guarantee future performance, and subject to change.

LITHIUM PRIMARY BATTERY

SB-D02



Key Characteristics

- High and stable operating voltage
- Low self-discharge rate (less than 1% after 1 year of storage at +20°C)
- Bobbin type
- Non-flammable inorganic electrolyte
- Hermetic glass-to-metal sealing
- UL recognized (file number MH18384)
- RoHS Compliance



External Dimensions

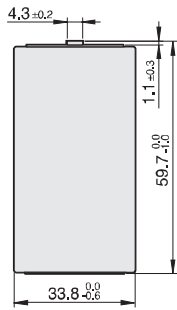

※ Available Terminals:
TC ST AX Other type
available by request

Specifications

Model	SB-D02
Nominal voltage	3.6V
Nominal capacity (at 6mA, 20°C, 2.0V cut off)	19.0Ah
Maximum recommended continuous current (Higher currents are possible, consult Vitzrocell)	100mA
Max. pulse discharge current	250mA
Weight	100.0g
Operating temperature range	-55 ~ 85°C

※ Max. pulse current/0.1 second pulses, drained every 2 min at +20°C from undischarged cells with 10 μA base current, yield voltage readings above 3.0V. The readings may vary according to the pulse characteristics, the temperature, and the cell's previous history.

Fitting the cell with a capacitor may be recommended in severe conditions. Consult Vitzrocell.

Characteristic Curve

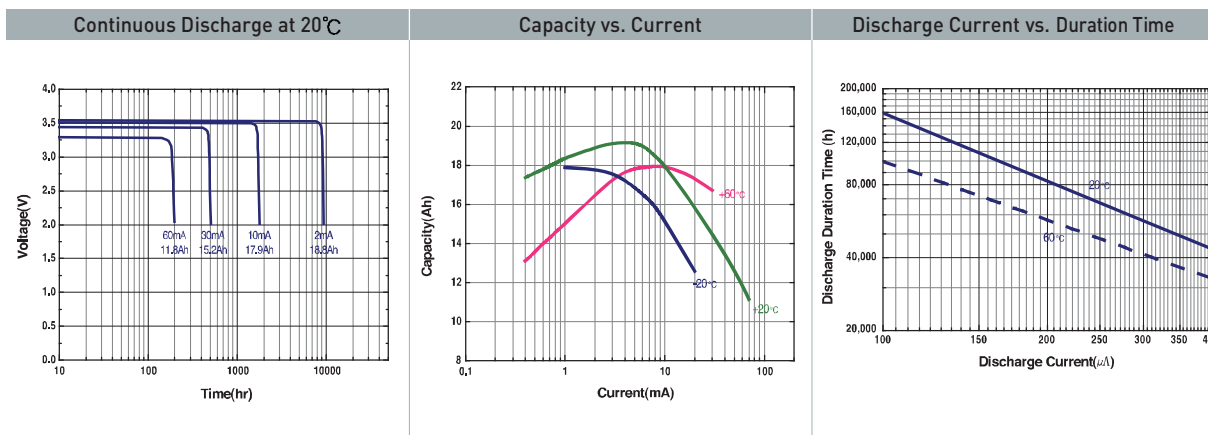

※ This data was made on basis of nominal capacity for the purpose of enabling users to forecast approximate life time. In order to calculate precise life time under various environments, we recommend you to consult Vitzrocell.

Warning

Fire, explosion and severe burn hazard. Do not recharge, crush, disassemble, heat above 212°F(100°C), incinerate, short circuit or expose contents to water. Keep battery out of reach of children and in original package until ready to use. Dispose of used batteries promptly.

※ Any information given here is for reference only. Information is also dependent on actual conditions of use and does not guarantee future performance, and subject to change.

LITHIUM PRIMARY BATTERY SB-D02(2F)



Key Characteristics

- High and stable operating voltage
- Non-flammable inorganic electrolyte
- High pulse current can be used
- Non-restricted for transport



External Dimensions

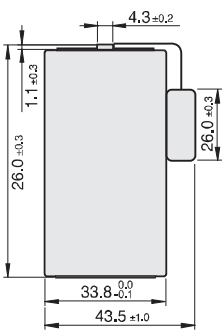

※ Available Terminals :
TC ST 2P 3P 3PW
Other type available
by request

Specifications

Hybrid Battery : (SB-D02) + EDLC (2.0F EDLC)

Model	HSB-D02 (2F)
Nominal voltage	3.6V
Nominal capacity (at 6mA, 20°C, 2.0V cut off)	19Ah
Max. 0.1s Pulse current to 3.0V	5A
Max. Pulse length at 1A	2Sec
Weight	g
Operating temperature range	-55 ~ 85°C

※ Max. pulse current/0.1 second pulses, drained every 2 min at + 20 °C from undischarged cells with 10 μA base current, yield voltage readings above 3.0V. The readings may vary according to the pulse characteristics, the temperature, and the cell's previous history.

Fitting the cell with a capacitor may be recommended in severe conditions. Consult Vitzrocell.

※ Before using the product, consult with VITZROCELL

Characteristic Curve

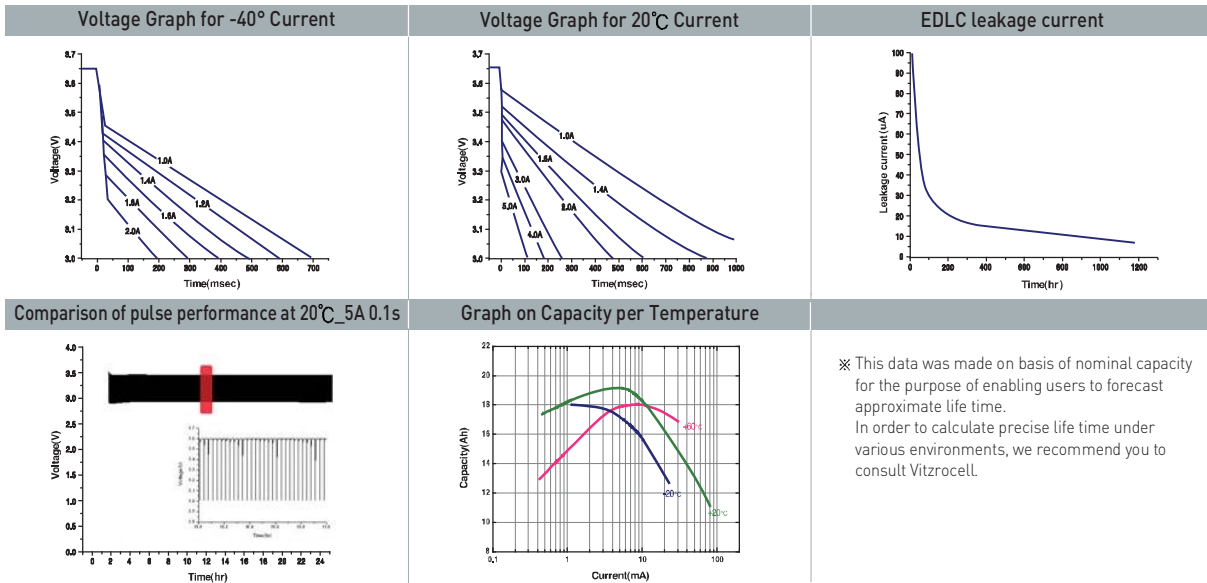

※ This data was made on basis of nominal capacity for the purpose of enabling users to forecast approximate life time. In order to calculate precise life time under various environments, we recommend you to consult Vitzrocell.

Warning

Fire, explosion and severe burn hazard. Do not recharge, crush, disassemble, heat above 212°F(100°C), incinerate, short circuit or expose contents to water. Keep battery out of reach of children and in original package until ready to use. Dispose of used batteries promptly.

※ Any information given here is for reference only. Information is also dependent on actual conditions of use and does not guarantee future performance, and subject to change.

LITHIUM PRIMARY BATTERY

SW-AA01



Key Characteristics

- High and stable operating voltage
- Low self-discharge rate (less than 2% after 1 year of storage at +20°C)
- Superior pulse capability
- Spiral type (with safety vent)
- Non-flammable inorganic electrolyte
- Hermetic glass-to-metal sealing
- RoHS Compliance
- Non-restricted for transport



External Dimensions

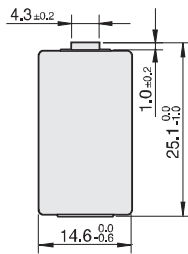

※ Available Terminals :
TC ST 2P 3P 3PW Other
type available by request

Specifications

Model	SW-AA01
Nominal voltage	3.6V
Nominal capacity (at 1mA, 20°C, 2.0V cut off)	0.8Ah
Maximum recommended continuous current (Higher currents are possible, consult Vitzrocell)	100mA
Max. pulse discharge current	300mA
Weight	9.0g
Operating temperature range	-55 ~ 85°C

※ Max. pulse current/0.1 second pulses, drained every 2 min at +20°C from undischarged cells with 10 μA base current, yield voltage readings above 3.0V. The readings may vary according to the pulse characteristics, the temperature, and the cell's previous history.
Fitting the cell with a capacitor may be recommended in severe conditions. Consult Vitzrocell.

Characteristic Curve

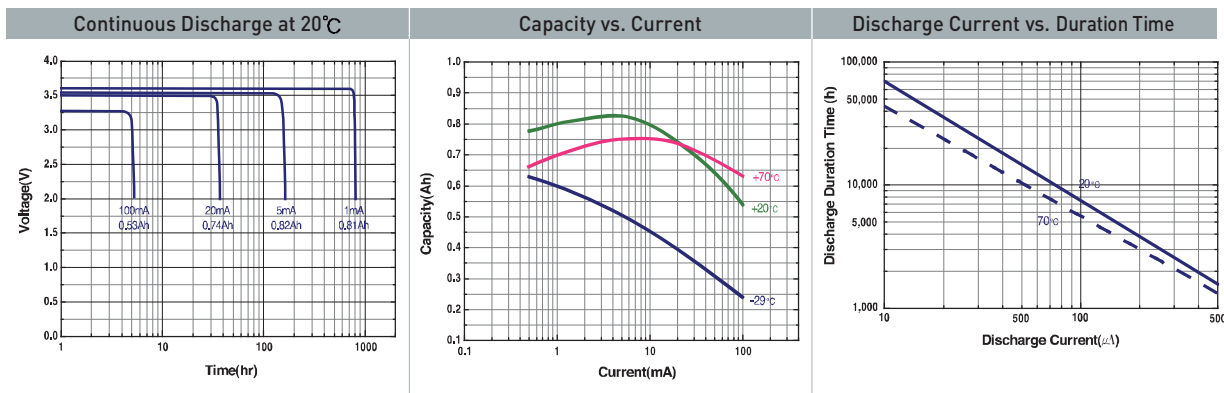

※ This data was made on basis of nominal capacity for the purpose of enabling users to forecast approximate life time. In order to calculate precise life time under various environments, we recommend you to consult Vitzrocell.

Warning

Fire, explosion and severe burn hazard. Do not recharge, crush, disassemble, heat above 212°F (100°C), incinerate, short circuit or expose contents to water. Keep battery out of reach of children and in original package until ready to use. Dispose of used batteries promptly.

※ Any information given here is for reference only. Information is also dependent on actual conditions of use and does not guarantee future performance, and subject to change.

LITHIUM PRIMARY BATTERY SW-AA11



Key Characteristics

- High and stable operating voltage
- Low self-discharge rate (less than 2% after 1 year of storage at +20°C)
- Superior pulse capability
- Spiral type (with safety vent)
- Non-flammable inorganic electrolyte
- Hermetic glass-to-metal sealing
- RoHS Compliance
- Non-restricted for transport



External Dimensions

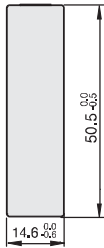

※ Available Terminals :
FF ST 2P 3P 3PW Other type
available by request



Specifications

Model	SW-AA11
Nominal voltage	3.6V
Nominal capacity (at 3mA, 20°C, 2.0V cut off)	2.0Ah
Maximum recommended continuous current (Higher currents are possible, consult Vitzrocell)	250mA
Max. pulse discharge current	800mA
Weight	17.0g
Operating temperature range	-55 ~ 85°C

※ Max. pulse current/0.1 second pulses, drained every 2 min at +20°C from undischarged cells with 10 μA base current, yield voltage readings above 3.0V. The readings may vary according to the pulse characteristics, the temperature, and the cell's previous history.
Fitting the cell with a capacitor may be recommended in severe conditions. Consult Vitzrocell.

Characteristic Curve

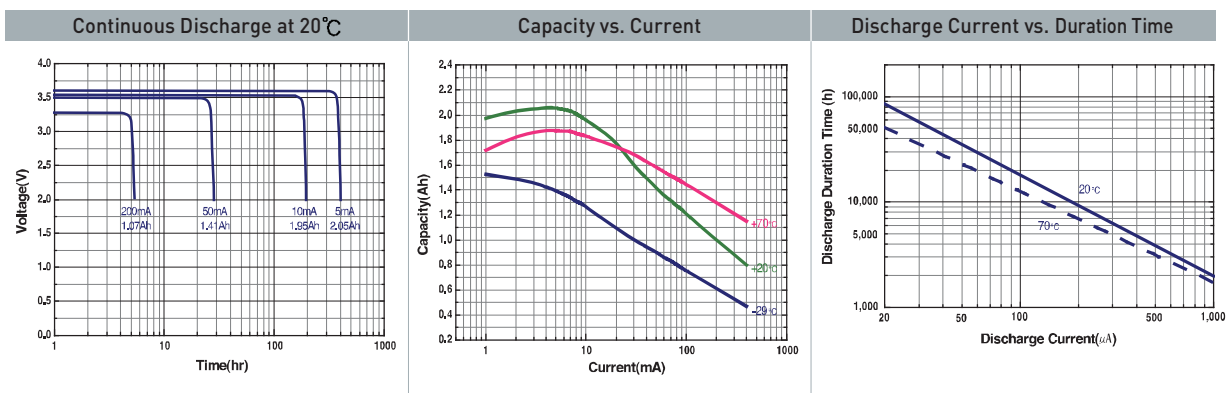

※ This data was made on basis of nominal capacity for the purpose of enabling users to forecast approximate life time.
In order to calculate precise life time under various environments, we recommend you to consult Vitzrocell.

Warning

Fire, explosion and severe burn hazard. Do not recharge, crush, disassemble, heat above 212°F(100°C), incinerate, short circuit or expose contents to water. Keep battery out of reach of children and in original package until ready to use. Dispose of used batteries promptly.

※ Any information given here is for reference only. Information is also dependent on actual conditions of use and does not guarantee future performance, and subject to change.

LITHIUM PRIMARY BATTERY

SW-A01



Key Characteristics

- High and stable operating voltage
- Low self-discharge rate (less than 2% after 1 year of storage at +20°C)
- Superior pulse capability
- Spiral type (with safety vent)
- Non-flammable inorganic electrolyte
- Hermetic glass-to-metal sealing
- RoHS Compliance



External Dimensions

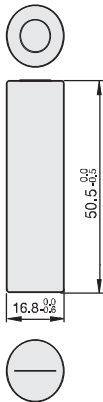

※ Available Terminals :
FF ST 2P 3P 3PW Other type
available by request

Specifications

Model	SW-A01
Nominal voltage	3.6V
Nominal capacity (at 5mA, 20°C, 2.0V cut off)	3.0Ah
Maximum recommended continuous current (Higher currents are possible, consult Vitzrocell)	600mA
Max. pulse discharge current	1,500mA
Weight	30.0g
Operating temperature range	-55 ~ 85°C

※ Max. pulse current/0.1 second pulses, drained every 2 min at +20°C from undischarged cells with 10 μA base current, yield voltage readings above 3.0V. The readings may vary according to the pulse characteristics, the temperature, and the cell's previous history. Fitting the cell with a capacitor may be recommended in severe conditions. Consult Vitzrocell.

Characteristic Curve

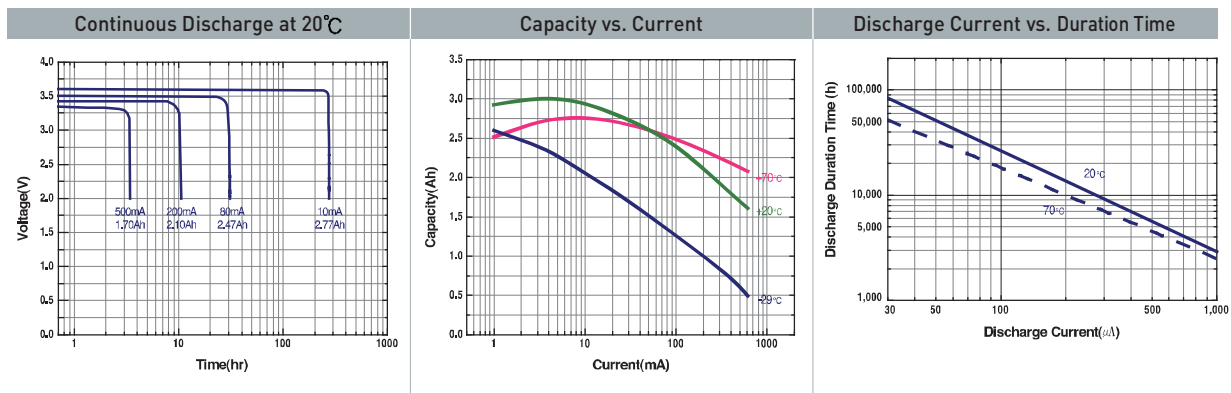

※ This data was made on basis of nominal capacity for the purpose of enabling users to forecast approximate life time. In order to calculate precise life time under various environments, we recommend you to consult Vitzrocell.

Warning

Fire, explosion and severe burn hazard. Do not recharge, crush, disassemble, heat above 212°F (100°C), incinerate, short circuit or expose contents to water. Keep battery out of reach of children and in original package until ready to use. Dispose of used batteries promptly.

※ Any information given here is for reference only. Information is also dependent on actual conditions of use and does not guarantee future performance, and subject to change.

LITHIUM PRIMARY BATTERY SW-C01



Key Characteristics

- High and stable operating voltage
- Low self-discharge rate (less than 2% after 1 year of storage at +20°C)
- Superior pulse capability
- Spiral type (with safety vent)
- Finished with 4A fuse
- Non-flammable inorganic electrolyte
- Hermetic glass-to-metal sealing
- UL recognized (file number MH18384)
- RoHS Compliance



External Dimensions

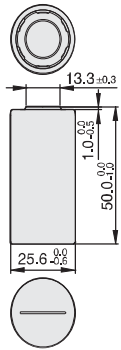

※ Available Terminals :
FF ST Other type available by request

Specifications

Model	SW-C01
Nominal voltage	3.6V
Nominal capacity (at 15mA, 20°C, 2.0V cut off)	6.0Ah
Maximum recommended continuous current (Higher currents are possible, consult Vitzrocell)	900mA
Max. pulse discharge current	1,800mA
Weight	52.0g
Operating temperature range	-55 ~ 85°C

※ Max. pulse current/0.1 second pulses, drained every 2 min at +20°C from undischarged cells with 10 μA base current, yield voltage readings above 3.0V. The readings may vary according to the pulse characteristics, the temperature, and the cell's previous history.
Fitting the cell with a capacitor may be recommended in severe conditions. Consult Vitzrocell.

Characteristic Curve

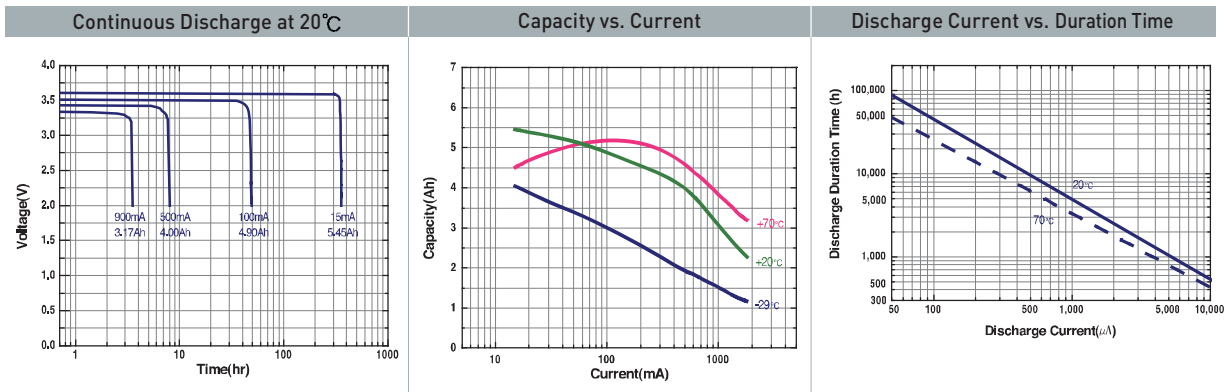

※ This data was made on basis of nominal capacity for the purpose of enabling users to forecast approximate life time. In order to calculate precise life time under various environments, we recommend you to consult Vitzrocell.

Warning

Fire, explosion and severe burn hazard. Do not recharge, crush, disassemble, heat above 212°F(100°C), incinerate, short circuit or expose contents to water. Keep battery out of reach of children and in original package until ready to use. Dispose of used batteries promptly.

※ Any information given here is for reference only. Information is also dependent on actual conditions of use and does not guarantee future performance, and subject to change.

LITHIUM PRIMARY BATTERY

SW-D02



Key Characteristics

- High and stable operating voltage
- Low self-discharge rate (less than 2% after 1 year of storage at +20°C)
- Superior pulse capability
- Spiral type (with safety vent)
- Finished with 4A fuse
- Non-flammable inorganic electrolyte
- Hermetic glass-to-metal sealing
- UL recognized (file number MH18384)
- RoHS Compliance



External Dimensions

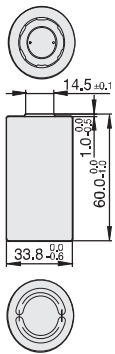

※ Available Terminals :
FF ST Other type available by request

Specifications

Model	SW-D02
Nominal voltage	3.6V
Nominal capacity (at 20mA, 20°C, 2.0V cut off)	14.0Ah
Maximum recommended continuous current (Higher currents are possible, consult Vitzrocell)	1,800mA
Max. pulse discharge current	3,000mA
Weight	102.0g
Operating temperature range	-55 ~ 85°C

※ Max. pulse current/0.1 second pulses, drained every 2 min at +20°C from undischarged cells with 10 μA base current, yield voltage readings above 3.0V. The readings may vary according to the pulse characteristics, the temperature, and the cell's previous history.
Fitting the cell with a capacitor may be recommended in severe conditions. Consult Vitzrocell.

Characteristic Curve

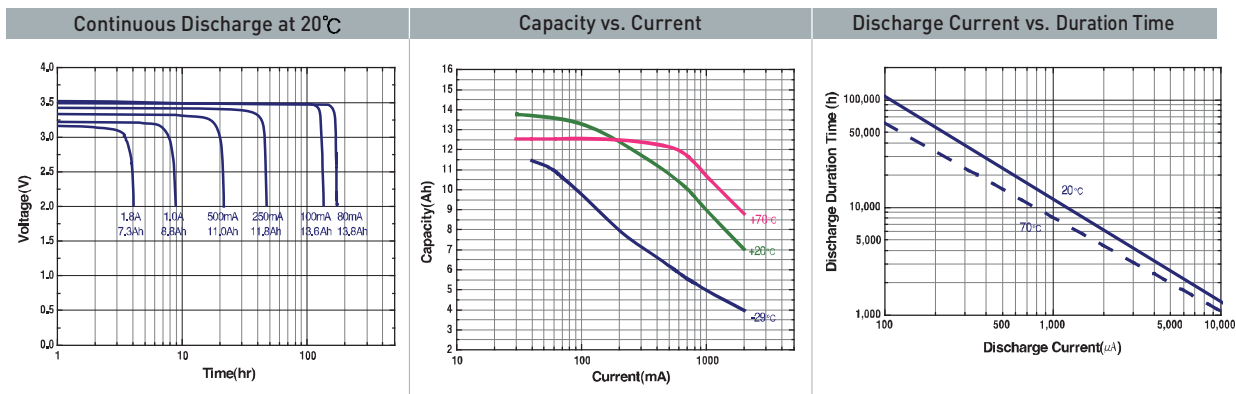

※ This data was made on basis of nominal capacity for the purpose of enabling users to forecast approximate life time. In order to calculate precise life time under various environments, we recommend you to consult Vitzrocell.

Warning

Fire, explosion and severe burn hazard. Do not recharge, crush, disassemble, heat above 212°F (100°C), incinerate, short circuit or expose contents to water. Keep battery out of reach of children and in original package until ready to use. Dispose of used batteries promptly.

※ Any information given here is for reference only. Information is also dependent on actual conditions of use and does not guarantee future performance, and subject to change.

LITHIUM PRIMARY BATTERY

CR123A



Key Characteristics

- High and stable operating voltage
- Low self-discharge rate (less than 2% after 1 year of storage at +20°C)
- UL recognized (file number MH18384)
- RoHS Compliance
- Non-restricted for transport



External Dimensions

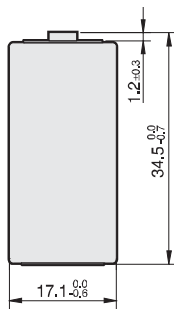

※ Available Terminals :
TC FF ST 2P 3P 3PW Other
type available by request

Specifications

Model	CR123A
Nominal voltage	3.0V
Nominal capacity (at 14mA, 20°C, 2.0V cut off)	1,500mAh
Maximum recommended continuous current (Higher currents are possible, consult Vitzrocell)	1,000mA
Max. pulse discharge current	3,500mA
Weight	16.0g
Operating temperature range	-30 ~ 60°C

※ Max. pulse current/0.1 second pulses, drained every 2 min at +20°C from undischarged cells with 10 μ A base current, yield voltage readings above 2.0V. The readings may vary according to the pulse characteristics, the temperature, and the cell's previous history.
Fitting the cell with a capacitor may be recommended in severe conditions. Consult Vitzrocell.

Characteristic Curve

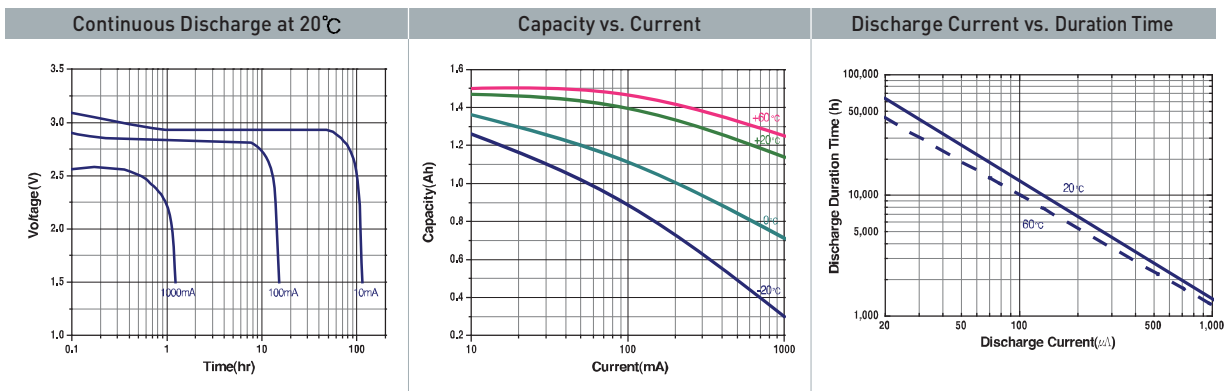

※ This data was made on basis of nominal capacity for the purpose of enabling users to forecast approximate life time.
In order to calculate precise life time under various environments, we recommend you to consult Vitzrocell.

Warning

Fire, explosion and severe burn hazard. Do not recharge, crush, disassemble, heat above 212°F(100°C), incinerate, short circuit or expose contents to water. Keep battery out of reach of children and in original package until ready to use. Dispose of used batteries promptly.

※ Any information given here is for reference only. Information is also dependent on actual conditions of use and does not guarantee future performance, and subject to change.

LITHIUM PRIMARY BATTERY

CR2



Key Characteristics

- High and stable operating voltage
- Low self-discharge rate (less than 2% after 1 year of storage at +20°C)
- UL recognized (file number MH18384)
- RoHS Compliance
- Non-restricted for transport



External Dimensions

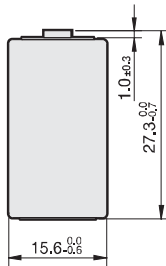

※ Available Terminals :
TC FF ST 2P 3P 3PW
Other type available by request

Specifications

Model	CR2
Nominal voltage	3.0V
Nominal capacity (at 10mA, 20°C, 2.0V cut off)	850mAh
Maximum recommended continuous current (Higher currents are possible, consult Vitzrocell)	800mA
Max. pulse discharge current	2,500mA
Weight	11.5g
Operating temperature range	-30 ~ 60°C

※ Max. pulse current/0.1 second pulses, drained every 2 min at +20°C from undischarged cells with 10 μA base current, yield voltage readings above 2.0V. The readings may vary according to the pulse characteristics, the temperature, and the cell's previous history.
Fitting the cell with a capacitor may be recommended in severe conditions. Consult Vitzrocell.

Characteristic Curve

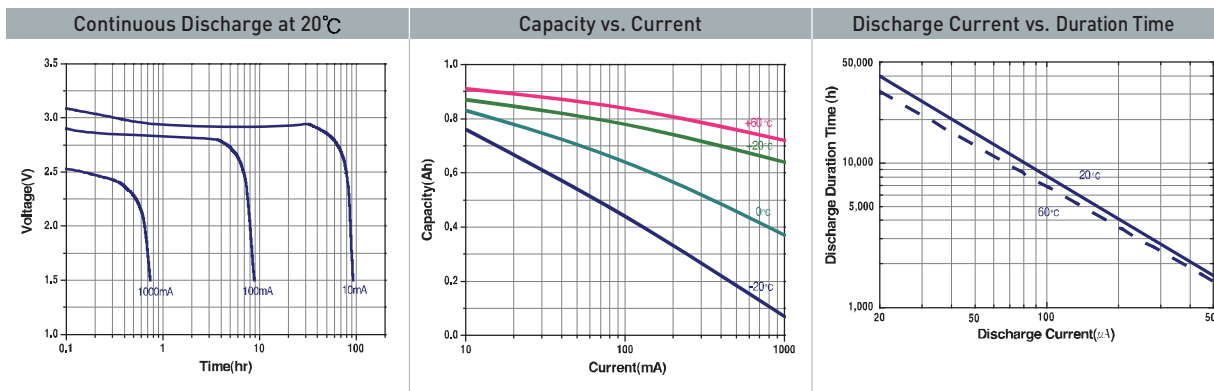

※ This data was made on basis of nominal capacity for the purpose of enabling users to forecast approximate life time. In order to calculate precise life time under various environments, we recommend you to consult Vitzrocell.

Warning

Fire, explosion and severe burn hazard. Do not recharge, crush, disassemble, heat above 212°F (100°C), incinerate, short circuit or expose contents to water. Keep battery out of reach of children and in original package until ready to use. Dispose of used batteries promptly.

※ Any information given here is for reference only. Information is also dependent on actual conditions of use and does not guarantee future performance, and subject to change.

LITHIUM PRIMARY BATTERY

EDLC Line Up

Features

- Can be used as a high pulse power and long cycle life application.
- It does not contain toxic materials such as nickel and cadmium.

Product List

Series	Part Number	Rated Voltage[V]	Capacitance[F]	ESR (AC 1kHz)[mΩ]	Range of Temperature[°C]	Size[mm] Unit(∅×L, Module(W×D×H))
VMPH	VMPH 5R0 754	5.0	0.75	≤250	-25~70	8.0×16.5×21.0
	VMPH 5R0 155		1.5	≤180		10.0×20.5×21.0
	VMPH 5R0 205		2.0	≤150		10.0×20.5×26.0
VMPL	VMPL 5R0 754	5.0	0.75	≤100	-40~60	8.0×16.5×21.0
	VMPL 5R0 155		1.5	≤70		10.0×20.5×21.0
	VMPL 5R0 205		2.0	≤60		10.0×20.5×26.0
DRMH	DRMH 5R0 504	5.0	0.5	≤900	-25~70	8.0×16.5×14.0
	DRMH 5R0 505		5.0	≤225		10.0×20.5×26.0
	DRMH 5R0 755		7.0	≤150		
DRML	DRML 5R0 504	5.0	0.5	≤600	-40~60	8.0×16.5×14.0
	DRML 5R0 505		5.0	≤105		10.0×20.5×26.0
	DRML 5R0 755		7.5	≤90		

Part Number System

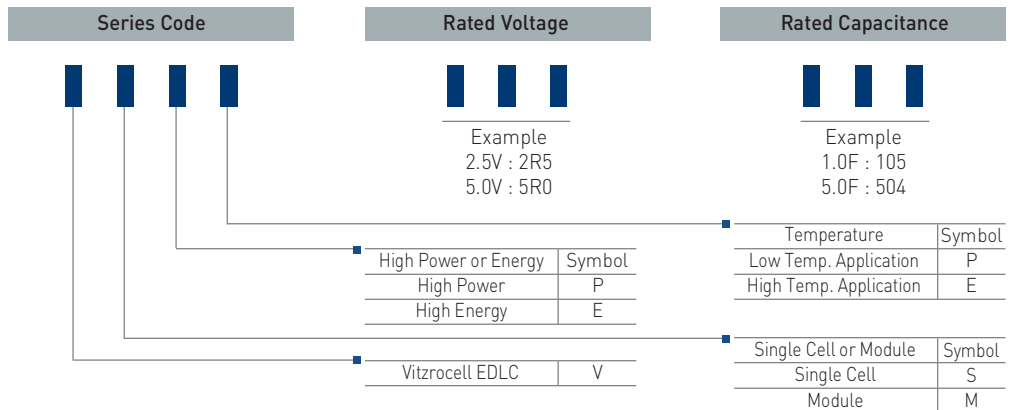

Outline Drawing



(Line up of Vitrocap.)

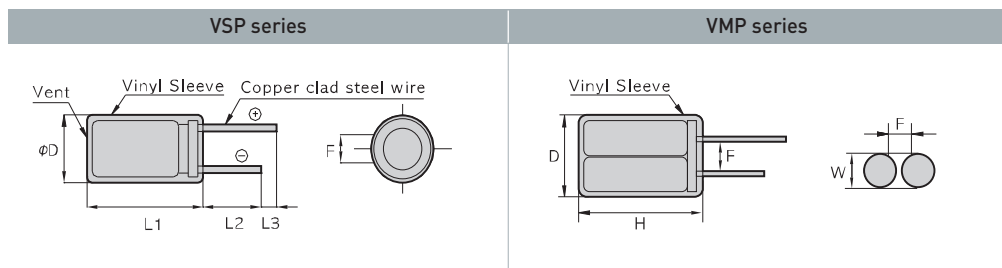

LITHIUM PRIMARY BATTERY

Military Pack



Item	BA-6853AK		BA-300K		BA-6813AK	
	Specification	Remark	Specification	Remark	Specification	Remark
Nominal Voltage[V]	14.4	Open Circuit Voltage(OCV)	28.4	Open Circuit Voltage(OCV)	10.8	Open Circuit Voltage(OCV)
Nominal Capacity[Ah]	13.0	at 20mA, 20°C, 8V cut off	26.0	at 40mA, 20°C, 16V cut off	13.0	at 40mA, 20°C, 16V cut off
Pack Construction	4 Series	Unit Cell: SW-D02	8 Series×2 Parallel	Unit Cell: SW-D02	3 Series	Unit Cell: SW-D02
Life Time as Temperature(Hr)	16 (60°C)	at 6.5Ω 1min, 50Ω 9min pulse discharge, 10V cut-off	26 (54°C)	at 32Ω continuous discharge, 19.2V cut-off	11 (60°C)	at 131Ω continuous discharge, 7.5V cut-off
	20 (21°C)		26 (21°C)		15 (21°C)	
	8 (-32°C)		6 (-29°C)		5 (-32°C)	
Dimension[mm]	102×72×65.7	W×D×H	189×146×71.5	W×D×H	210×40×40	W×D×H
Weight[g]	500		3,000		450	
NSN	6135-37-511-2825	National Stock Number	6135-37-502-0931	National Stock Number	6135-37-511-2828	National Stock Number
Main Application	PRC-999K	FM Radio Set	SB-30K	Changer for filed operation	ADU-95	Automatic Decode Unit
Shelf Life(years)	5		5		5	



Item	BA-6818AK		BA-6802K		BA-6821AK	
	Specification	Remark	Specification	Remark	Specification	Remark
Nominal Voltage[V]	14.4	Open Circuit Voltage(OCV)	7.2	Open Circuit Voltage(OCV)	32.4	Open Circuit Voltage(OCV)
Nominal Capacity[Ah]	13.0	at 20mA, 20°C, 8V cut off	13.0	at 20mA, 20°C, 4V cut off	13.0	at 20mA, 20°C, 18V cut off
Pack Construction	4 Series	Unit Cell: SW-D02	2 Series	Unit Cell: SW-D02	9 Series	Unit Cell: SW-D02
Life Time as Temperature(Hr)	15 (60°C)	at 6.5Ω 1min, 50Ω 9min pulse discharge, 10V cut-off	23 (54°C)	at 15Ω continuous discharge, 4V cut-off	21 (60°C)	at 11Ω 1min, 110Ω 9min pulse discharge, 21V cut-off
	18 (21°C)		22 (21°C)		23 (21°C)	
	9 (-20°C)		4 (-25°C)		14 (-20°C)	
Dimension[mm]	210×40×40	W×D×H	36×135	∅XL	207×76×77	W×D×H
Weight[g]	550		240		1,200	
NSN	6135-37-511-2827	National Stock Number	6135-37-509-7092	National Stock	6135-37-511-2826	National Stock Number
Main Application	ARF-95	Security Device	K-CAM	NumberChemical Detector	PRC-950K	AM Radio Set
Shelf Life(years)	5		5		5	



Item	BA-6863K		BA-6812K		BA-6086K	
	Specification	Remark	Specification	Remark	Specification	Remark
Nominal Voltage(V)	14.4	Open Circuit Voltage(OCV)	7.2	Open Circuit Voltage(OCV)	10.8	Open Circuit Voltage(OCV)
Nominal Capacity(Ah)	26.0	at 5mA, 20°C, 8.0V cut off	13.0	at 20mA, 20°C, 4V cut off	4.0	at 16mA, 20°C, 6V cut off
Pack Construction	4 SeriesX2 Parallel	Unit Cell: SW-D02	2 Series	Unit Cell: SW-D02	3 SeriesX2 Parallel	Unit Cell: SW-AA11
Life Time as Temperature(Hr)	9 (54°C)	at 6.5 Ω 1min, 3.2 Ω 9min pulse discharge, 7V cut-off	16 (54°C)	at 10 Ω continuous discharge, 5.5V cut-off	12 (54°C)	at 11 Ω 1min, 50 Ω 1min, 265 Ω 8min, pulse discharge, 6V cut-off
	9 (21°C)		12 (21°C)		12 (21°C)	
	5 (-20°C)		3 (-20°C)		6 (-29°C)	
Dimension(mm)	170×72.2×65.7	W×D×H	38×135	∅XL	130×16×58	W×D×H
Weight(g)	1,000		250		160	
NSN	6135-37-509-8121	National Stock	6135-37-507-8697	National Stock	6135-37-506-5009	National Stock Number
Main Application	VRC-680AK	Number Portable Terminal Set	PAS-01K	Number Heat Reflection Sight	PRC-96K	Communication Device
Shelf Life(years)	5		5		5	



Item	BA-6218K		BA-6012K		BA-6085K	
	Specification	Remark	Specification	Remark	Specification	Remark
Nominal Voltage(V)	18.0	Open Circuit Voltage(OCV)	7.2	Open Circuit Voltage(OCV)	14.4	Open Circuit Voltage(OCV)
Nominal Capacity(Ah)	4.0	at 6mA, 20°C, 10.0V cut off	4.0	at 6mA, 20°C, 4V cut off	2.0	at 3mA, 20°C, 8V cut off
Pack Construction	5 SeriesX2 Parallel	Unit Cell: SW-AA11	2 SeriesX2 Parallel	Unit Cell: SW-AA11	4 Series	Unit Cell: SW-AA11
Life Time as Temperature(Hr)	55 (50°C)	at 10 Ω continuous discharge, 10V cut-off	60 (54°C)	at 140 Ω continuous discharge, 4.5V cut-off	30 (54°C)	at 65 Ω 5sec, 200 Ω 5sec, 336 Ω 40sec, pulse discharge, 10V cut-off
	55 (21°C)		60 (21°C)		29 (21°C)	
	48 (-35°C)		45 (-29°C)		7 (-29°C)	
Dimension(mm)	78×54×45	W×D×H	59×55.3×17	W×D×H	55×32×35	W×D×H
Weight(g)	220		100		100	
NSN	6135-37-505-3618	National Stock Number	6135-37-508-7363	National Stock Number	6135-37-502-8021	National Stock Number
Main Application	PRG-1831K	Remote Explosion Device	PDR-1K	Radiation Device	PRC-85K	Communication Device
Shelf Life(years)	5		5		5	

Battery Application Worksheet

Company Information

Company	
Name	E-Mail
Department	Tel.
Address	Fax.

Physical Requirements		
Battery type & Pack construction	Li/SOCl ₂ , Li/MnO ₂	(series, parallel)
Application	Terminal or connector	Cable

Electrical Requirements

Capacity	Expected life time
Cut-off voltage (Minimum operating voltage)	Maximum operating voltage

Current profile

Ex)

	Current(mA)	Duration(sec)	Interval(sec)
Base current		X	X
Pulse1			
Pulse2			
Pulse3			

Environmental Requirements





Storage Temperature (min, mean, max)	Operating Temperature (min, mean, max)
--------------------------------------	--

Additional Information

LITHIUM PRIMARY BATTERY

Available Terminals

Available Terminals

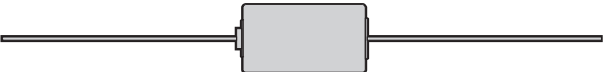
TC Type	
ST Type	
2P Type	
3P Type	
3PW Type	
AX Type	

Technical List

Product List

Type	Size	Model	IEC	Nominal Voltage (V)	Nominal Capacity (Ah)	Standard Discharge Current(mA)	Maximum Continuous Discharge Current(mA)	Maximum Pulse Discharge Current (mA)	Temperature Range(°C)	Weight (g)	Data sheet
Li/SOCL ₂ Bobbin type	1/2AA	SB-AA02	ER14250	3.6	1.2	1	20	50	-55-85	9.0	P. 4
		SB-AA02(P)	ER14250	3.6	1.2	1	20	80	-55-85	9.0	P. 5
	AA	SB-AA11	ER14500	3.6	2.5	2	60	100	-55-85	16.0	P. 6
		SB-AA11(P)	ER14500	3.6	2.5	2	60	150	-55-85	16.0	P. 7
	A	SB-A01	ER17500	3.6	3.65	3	70	160	-55-85	24.0	P. 8
	C	SB-C02	ER26500	3.6	8.5	4	80	180	-55-85	51.0	P. 9
	D	SB-D02	ER33600	3.6	19.0	6	100	250	-55-85	100.0	P. 10
Li/SOCL ₂ Spiral type	1/2AA	SW-AA01	ER14250	3.6	0.8	1	100	300	-55-85	9.0	P. 11
	AA	SW-AA11	ER14500	3.6	2.0	3	250	800	-55-85	17.0	P. 12
	A	SW-A01	ER17500	3.6	3.0	5	600	1,500	-55-85	30.0	P. 13
	C	SW-C01	ER26500	3.6	6.0	15	900	1,800	-55-85	52.0	P. 14
	D	SW-D02	ER33600	3.6	14.0	20	1,800	3,000	-55-85	102.0	P. 15
Li/BCX	D	BW-D01		3.9	12.0				-55-85	102.0	
Li/MnO ₂	2/3A	CR123A	CR17350	3.0	1.5	14	1,000	3,500	-30-60	16.0	P. 16
		CR2	CR16270	3.0	0.8	10	800	2,500	-30-60	11.5	P. 17

※ Various terminals such as pin, wire, connector and etc. are also available by request

 Packing Information

Type	Model	Unit/Packing	Net Wt. (g)	Inner Box		Outer Box				
				Q' ty(pcs)	Net Wt.(g)	Q' ty(pcs)	Net Wt.(kg)	Gross Wt. (kg)	CBM	Dimension(mm)
Li/SOCL ₂ Bobbin type	SB-AA02(P)	1pc.(bulk)/TC,ST,P	9.2	100	980	1000	9.8	10.7	0.0337	510×330×200
		1pc.(bulk)/AX	9.2	30	316	300	3.2	4.1	0.0290	435×370×180
	SB-AA11(P)	1pc.(bulk)/TC,ST,P	16.0	100	1660	600	10.0	10.9	0.0337	510×330×200
		1pc.(bulk)/AX	16.0	25	440	250	4.4	5.3	0.0290	435×370×180
	SB-A01	1pc.(bulk)/TC,ST,P	24.0	90	2220	540	13.3	14.2	0.0337	510×330×200
	SB-C02	1pc.(bulk)/TC,ST,P	51.0	50	2610	300	15.7	16.6	0.0357	515×347×200
	SB-D02	1pc.(bulk)/TC,ST,P	100.0	30	3060	120	12.2	13.1	0.0337	510×330×200
Li/SOCL ₂ Spiral type	SW-AA01	1pc.(bulk)/TC,ST,P	9.2	100	980	1000	9.8	10.7	0.0337	510×330×200
	SW-AA11	1pc.(bulk)/TC,ST,P	17.0	100	1760	600	10.6	11.5	0.0337	510×330×200
	SW-A01	1pc.(bulk)/TC,ST,P	30.0	90	2775	540	16.7	17.6	0.0337	510×330×200
	SW-C01	1pc.(bulk)/TC,ST,P	51.0	50	2610	300	15.7	16.6	0.0357	515×347×200
	SW-D02	1pc.(bulk)/TC,ST,P	102.0	30	3120	120	12.5	13.4	0.0337	510×330×200
	BW-D01	1pc.(bulk)/TC,ST,P	102.0	30	3120	120	12.5	13.4	0.0337	510×330×200
	CR123A	1pc.(Blister)	16.0	10	210	200	4.7	5.3	0.0202	509×228×174
	CR-2	1pc.(Bulk)	11.5	100	1,649	800	13.2	14.0	0.0202	509×228×174
		1pc.(Blister)		10	159	200	3.7	4.3	0.0202	509×228×174
1pc.(Bulk)		40		539	960	12.9	13.7	0.0202	509×228×174	

LITHIUM PRIMARY BATTERY

Memo



Green Batteries for Smart Grid **INNOVATION TEKCELL**

TeKcell
LITHIUM PRIMARY BATTERY

VITZROCELL

LITHIUM PRIMARY BATTERY

VITZROCELL Co.,Ltd.

**Head Office
& Factory** Sinam agriculture and industry complex,
256-41 Dugok-li, Sinam-myun, Yesan-gun,
Chungcheongnam-do, South Korea 340-860
Tel : 82-41-332-8642
Fax : 8241-332-8646

Seoul Office VITZRO Bld. 241 Gunja-dong, Gwangjin-gu,
Seoul, South Korea 143-837
Tel: 82-2-2024-3244
Fax: 82-2-499-2756

VITZROCELL Agency

ЗАКАЗЫ ПО РОССИИ

ООО «Антарес», г. Санкт-Петербург,
ул. Коммуны, 16, литер А, офис 33

+7 (812) 646-54-88

office@vitzrocell.ru

www.vitzrocell.ru